

PANEL CUTOUT

PANEL THICKNESS	X
0.75 - 1.25	19.2
1.25 - 2.00	19.4
2.00 - 3.00	19.6

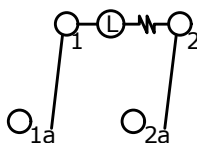

CIRCUIT: DPST

SWITCH FUNCTION	
POS. 1	POS. 2
OFF	ON
OPEN	1-1a, 2-2a

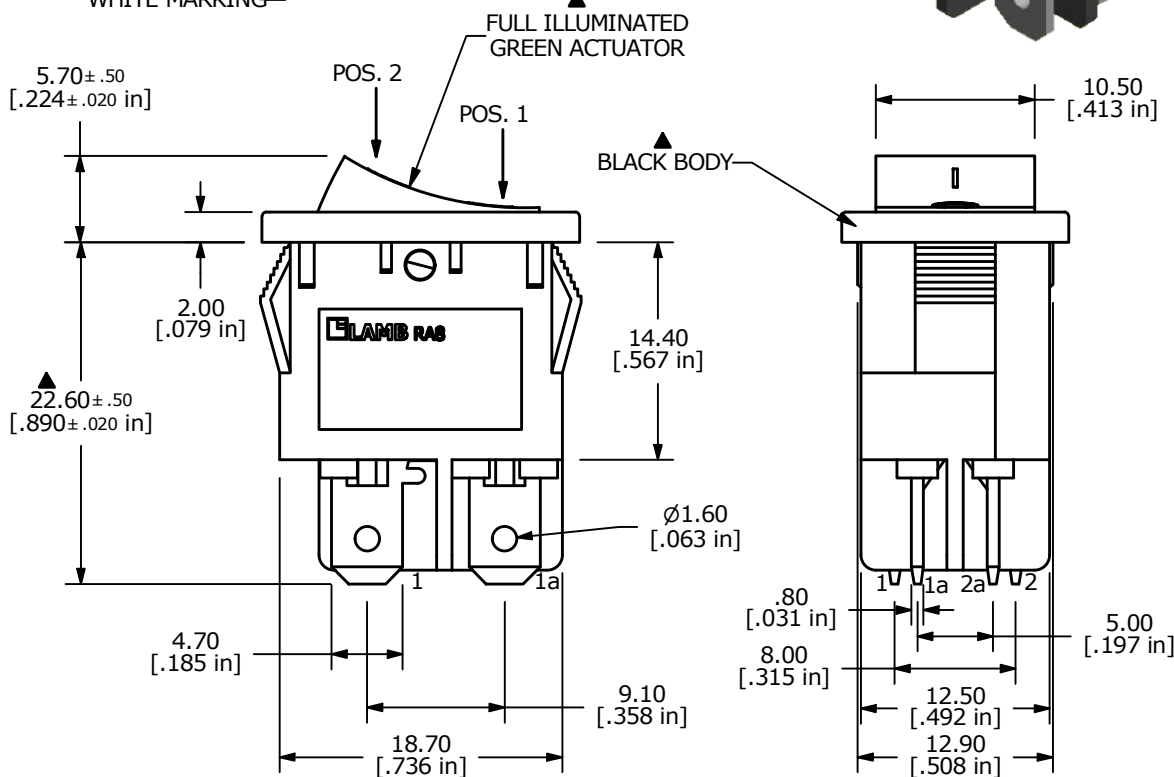
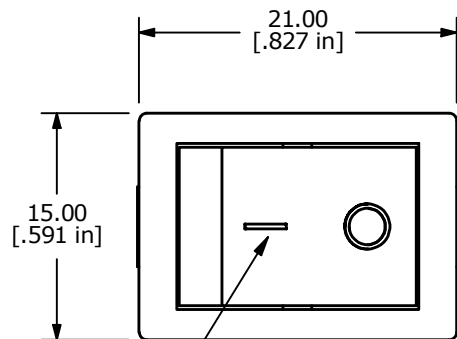

NOTE:

- DIMENSIONS IN MM [INCH]
- GENERAL TOLERANCE: X.X = ± 0.4  
X.XX = ± 0.25
- TERMINAL NUMBERS FOR REF ONLY
- CONTACT MATERIAL: SILVER
- CONTACT RATINGS: 16A @ 125VAC [UR, cUR]  
10A @ 250VAC [UR, cUR]  
1/3HP 125/250VAC [UR, cUR]
- CONTACT RESISTANCE: 35mΩ MAX. @ 50VAC
- INSULATION RESISTANCE: 100MΩ MIN. @ 500VAC
- DIELECTRIC STRENGTH: 1,500VAC FOR 1 MINUTE
- ELECTRICAL LIFE: 6,000 CYCLES [UR, cUR]
- OPERATING TEMPERATURE: -20°C TO 105°C [UR, cUR]
- ▲ DENOTES CRITICAL PARAMETER
- LAMP VOLTAGE: 250V

REV	ECO NO	DESCRIPTION	DATE	BY
B	ECO-100443	REMOVE VDE/ENEC RATING AND LOGO	01/12/22	JS



OBJECT ID  
000001447

TITLE RA812C1021-137				
SCALE 2:1	DATE 7/21/2011	DR BGL	DWG 38-RA812C1021137	REV B